

This information has been taken from the book

# Sampler Schoolhouse

Copyrighted 1996

Written by  
Brenda Henning



Bear Paw Productions

---

PO Box 230589 • Anchorage, AK 99523-0589

Phone (907) 349-7873 • FAX (907) 349-7875

[www.bearpawproductions.com](http://www.bearpawproductions.com)

# Selecting Fabric

**Fabric Selection** is one of the most important steps you will take when making your quilt. As a new quilter, or even for more experienced quilters, this is often the most difficult part of the entire quilting process. Just exactly where do you begin?

**Fiber Content** should be the first topic considered. Cotton has always been the fabric of choice for quilting. Cotton will take a crease well when the seams are pressed and forgive the quilter when it is necessary to ease a seam to fit. Cotton can be pressed at high temperatures and resist scorching. Read the bolt end of the fabric to determine fiber content. I recommend working with 100% cotton fabric.

As a general rule, it is not wise to mix fabric of different fiber contents within one quilt. Polyester is stronger than cotton. While this may not be readily apparent, over the life of the quilt the strength of the polyester fabric will weaken the adjacent cotton patches, possibly resulting in tears to the cotton patch.

For the same reason, I use only 100% cotton thread. I started piecing quilt tops twenty+ years ago. I used the thread that my mother had in the sewing cabinet. That thread was cotton covered polyester. After years of use and washing, the thread **cut** the fabric at the seam line because the thread was stronger than the cotton fabric. Cotton thread that is the same strength or weaker than the cotton fabric is the ideal selection. If the thread should weaken and break, the seam can be restitched. Fabric that has been destroyed is harder to replace.

**Focus Fabric** should be the first fabric selected. I call it focus fabric because it is the centerpiece for all of your other fabric choices. The focus fabric should be a multi-colored print, containing at least three or four color families that other fabrics can be pulled from. This fabric will generally appear as the final border and as one of the fabrics used in each block. Sometimes the focus fabric does not work well in the piecing of the blocks, but is the theme that helps the other fabrics to harmonize. Sometimes the focus fabric is used to select the other fabric pieces used in the quilt and is then discarded. There are no rules one is required to follow, only suggestions made from the vantage point of experience.

Now that you know what type of fabric you are looking for, where do you begin? Look for a multicolor "focus" fabric that contains your favorite color, a fabric that will compliment the color theme in the room where the quilt will be used, or select a multicolored fabric that you love and redecorate the chosen room around the colors in the focus fabric. The key here is that you should just **love** this fabric. It needs to satisfy your sense of taste, whether that be bright and vibrant, soft and pastel, or rich and deep.

**Do not** be tempted to purchase fabric just because it is less expensive. You truly do get what you pay for. Good quality fabric can certainly be found at your local quilt shop. I suggest that you start there when you are on your fabric quest. Quilt shops are staffed by friendly people that love to help you find just the right combination of fabrics.

**Coordinating Fabrics** should be selected with the focus fabric in mind. Three or four different color families should be represented. Each color family should include at least a medium value and a dark value of that base color, i.e., medium and dark blue, medium and dark green, medium and dark purple, etc. If your focus print can support four color families, select eight or more coordinating pieces. You may want to use a light value of each color family also. Just keep in mind that the fabrics need to have enough contrast that you can easily see where one fabric ends and the next fabric begins.

What type of prints should be used as coordinating fabrics? I use what I call **pseudo-solids**. Pseudo-solids are prints that "read" as solids from a distance. You may have heard them called tone-on-tone prints, or monotone prints. I try to avoid multicolor fabrics at this point because the use of more than one "focal" print becomes chaotic and causes the quilt to appear busy.

**Background Fabric** is most often light in color. I would suggest white on white prints, or white on muslin prints. Whatever you select, the color should contrast well with the other fabrics. It would be disappointing to toil over blocks and find that the piecing disappears because it lacks contrast.

**Scale of Print** should vary as much as the light and dark values of the fabric vary. When you are choosing fabric look for a balance of small, medium and large print size. Different scales of print add excitement to the quilt.

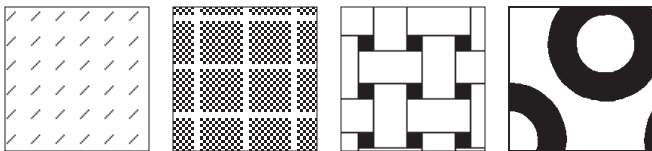

**Fabric Preparation** should be handled in the same manner that the quilt will be cared for when completed. I recommend prewashing all fabrics. As each piece enters my house, the first stop is the laundry room. All fabric in my personal stash has been washed.

How do you wash quilting cottons? First, fully open the fabric. Any fold allowed to remain in the fabric during washing could suffer dye loss and be permanently discolored. Wash like colors together in warm water using a mild soap. Dreft is a good soap available at the grocery. Orvus paste is a horse shampoo that is a fine product to use on cotton fabric and quilts. It is available from pet care stores. Rinse well; watch the final rinse to determine if any of the fabrics bleed color into the water. Dry the fabric in a warm dryer; take care to not over dry the fabric. Fold and store your fabric until later use.

**Do not** use detergents to wash your cotton fabrics. Detergents act to strip color from cotton fabrics.

If you have a piece of fabric that is bleeding color into the rinse water you will need to test the fabric to determine if the color is just escaping or if it will transfer onto other fabric. To do this, stitch a small piece of the offending fabric to pieces of the other fabrics you have chosen for that project. Wash the pieces as you plan to wash the completed quilt. If no color has transferred onto any of the other fabrics (compare test fabrics to the original yardage), the bleeding fabric is okay to be used in this project. If color has been transferred to the other pieces, pin a note indicating the problem to the offending fabric and put it away for another project that is not effected by this transfer of dye - perhaps a quilt that uses black as a background fabric.

To replace the firmness of the sizing that has been washed out of the fabric, press all fabrics using a heavy-duty spray starch. I use Faultless Heavy Starch. The fabric that is prepared in this way will behave much better when pressing seams, bias edges will be more stable and less likely to stretch, and you will find that piecing will be much easier with fabric that doesn't stretch out of shape so quickly.

# Cutting Fabric

## Rotary Cutting Tools

The **rotary cutter** is a razor knife that resembles a pizza cutter. The blade is very sharp and deserves to be treated with utmost respect. This amazing tool has revolutionized quilt making, nearly replacing the scissors. I recommend a rotary cutter that has a manual safety guard. Some rotary cutters available on the market have a spring-loaded guard that can accidentally retract when dropped, exposing the razor sharp blade and cutting your hand or foot. The spring-loaded guards protect you from only the most minor of blade "bumps." The rotary cutters that have a manually closing safety guard, such as Olfa® and Fiskar®, require that you consciously close the guard after every cut. Learn to make a habit of closing the guard every time!! An exposed blade on the work surface can lead to tragic results, accidentally cut fabric or worse cut fingers and bloodstained fabric. **Do not** leave a rotary cutter unattended around a curious toddler or young child.

I prefer to use the **Olfa®** rotary cutter. This particular rotary cutter can be used both right and left-handed without repositioning the blade.

To ensure the life of the blade, the rotary cutter must be used only on a compatible cutting surface. The self-healing **cutting mats** are a necessary tool. While the mats come in many sizes, purchase the largest cutting mat that you can afford. The 24" x 36" cutting mat is worth every dime.

**Omnigrid®** is my ruler of preference. The Omnigrid® brand is the most accurate of all rulers I have worked with. It is very important that all of your rulers are accurate and that they agree with each other. Compare the markings of all rulers in your collection. If any ruler does not measure up, discard it!! The markings on your rotary mat must also agree with the rulers you have chosen to use.

## Fabric Grain

Fabric grain is the direction of threads in a woven fabric. The selvages are the finished edges on either side of the length of fabric.

Lengthwise grain runs parallel to the selvage. The lengthwise grain of the fabric is the most stable. We use this to our advantage by cutting the final border along the lengthwise grain to minimize stretching.

Crosswise grain runs perpendicular to the selvage of the fabric. It is stretchier than lengthwise grain, but is stable enough to be placed at the edges of a block without causing difficulty.

Bias runs at a 45° angle to the selvage and has the most stretch. Bias requires careful handling to prevent distortion and is rarely placed at the edge of blocks because of its tendency to stretch.

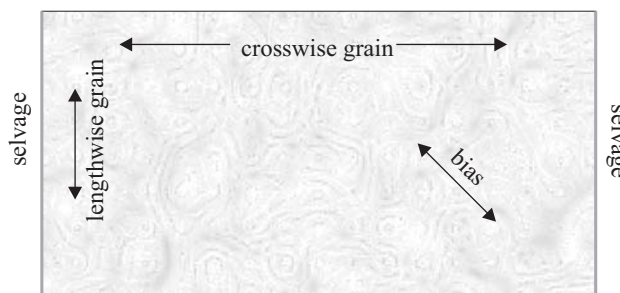

## Squaring Up Yardage

Fold your fabric in half lengthwise, wrong sides together, selvage edges even. You may need to shift one selvage to the right or left to eliminate wrinkles along the folded edge. Once this has been accomplished, fold the fabric again, lengthwise, bringing the folded edge even with the selvage edges. The fabric will now be folded into four thicknesses, and measure about 10 1/2" wide, allowing strips to be cut without repositioning your ruler hand.

Lay the folded fabric horizontally on your gridded cutting mat. The folded edge should be nearest you. Place the fold along a horizontal line of the mat. This will allow you to place your ruler along a vertical mat marking, guaranteeing a straight cut. If you are right-handed, the bulk of your fabric should be on the right, and you will start cutting from the left side. This will be reversed for a left-handed person.

The rotary cutter is held with the blade perpendicular to the mat and against the edge of the ruler. The rotary cutter is held in the palm of your hand with the index finger on the ridged surface of the handle. This placement helps you to better control the rotary cutter. You are in effect pointing it in the proper direction.

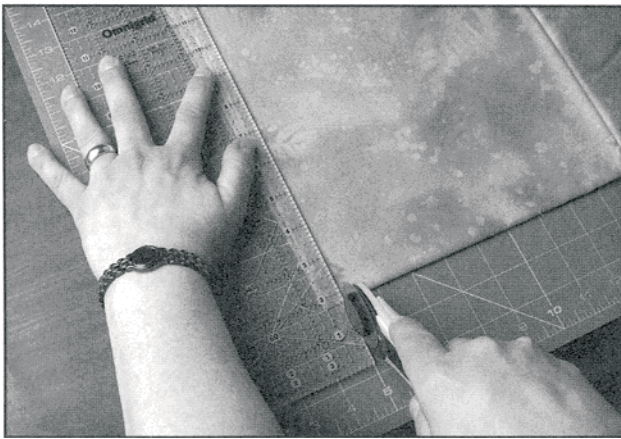

Cut away from yourself using one smooth even stroke. Do not make short choppy cuts which will create a ragged edge. The first cut will trim off the raw edge and square up the fabric. The clean edge will be perpendicular to the selvage. Trim sparingly to give the fabric a clean edge while wasting as little fabric as possible.

## Cutting Strips

After the original cut has been made to square up the end of the yardage, you are ready to cut your first strip.

Move the ruler to the right (left for a left-handed person) and align the squared off edge with the ruler marking for the strip width desired. Make sure that the correct marking lines up all along the cut edge, not just at one point!! Measure twice and cut once!!

Cut along the right (left) side of the ruler. Be sure to keep your blade flush against the ruler, do not allow the ruler to shift. Lift the ruler and remove the strip without disturbing the yardage.

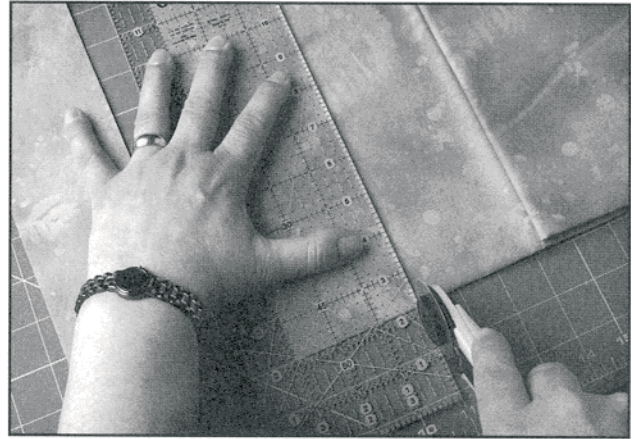

Open the strip and look at it closely. The strip should be straight and of a consistent width. If your strip is not straight, refold your fabric and make certain that the edges are even. Also, make sure the original cut was made correctly, perpendicular to the folded edge.

### The Dreaded Crooked Strip

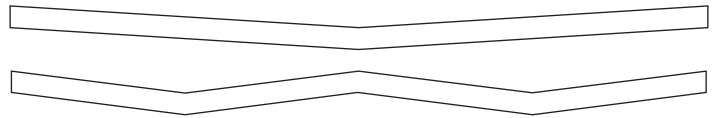

If it is necessary to cut a strip wider than your ruler, use the rulings of the cutting mat to measure the strip or square. Double check the mat measurements against that of your ruler to determine if the mat measurements are accurate.

## Subcutting Strips

Squares and rectangles needed for piecing will be cut from strips. Cut the strip to the required width and open the double fold. You will be working with two layers of fabric and a single fold. If you are right-handed, the selvages should be placed at the left. Trim off the first 1/2" to remove the selvages (more if needed) and square up the end of the strip. Use the mat markings to establish a perpendicular cut.

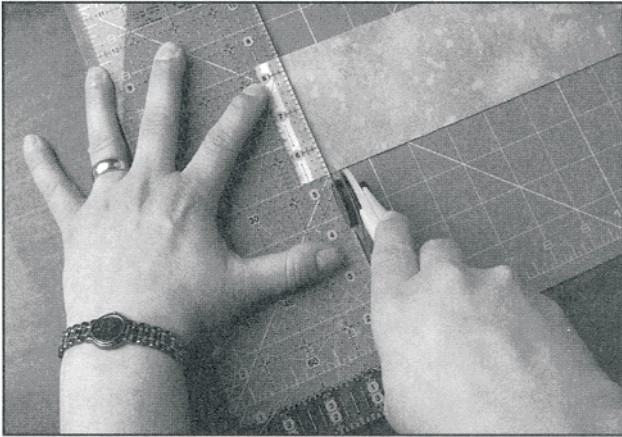

Align the top edge of the ruler with the edge of the fabric, the bottom edge of the fabric should line up with a ruler marking. Cut the squares or rectangles to the required dimension. Continue cutting from the strip to satisfy the number needed.

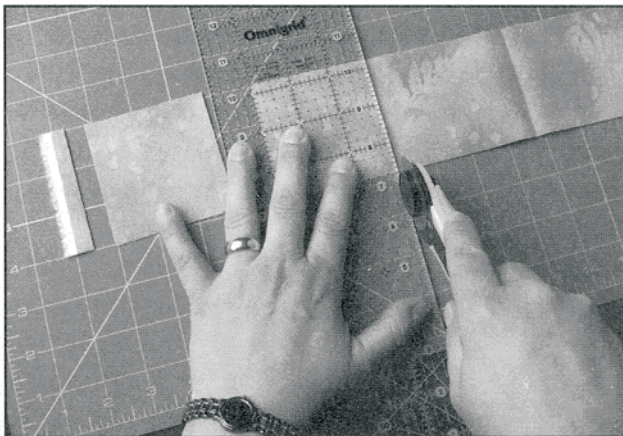

## Subcutting Diamonds

Diamonds are also cut from strips. The LeMoyne Star diamond is cut from a strip 3" wide.

Diamonds are best cut from an open strip - only one layer is cut - or multiple layers are cut, with all

layers facing right side up. This will place a straight-of-grain edge next to a bias edge when pieced, allowing for greater stability.

Place the strip of fabric horizontally on the cutting mat. The 45° angle marking of the ruler will be positioned along the bottom edge of the strip. Trim the fabric extending from the left edge of the ruler - turn the mat if necessary, to make the cut a right-handed cut. This establishes the true bias edge.

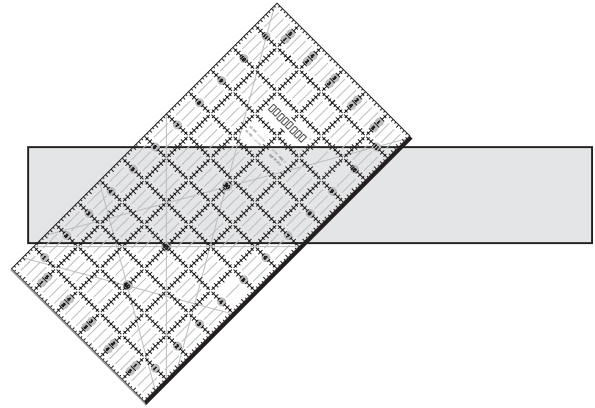

Measure to the right of the newly cut bias edge using the rulings on your rotary ruler. Cut along the right edge of the ruler. The resulting diamond is a true 45° diamond. The sides are all the same length and the narrow angles measure 45°. The secondary cut will measure 3" from the bias edge.

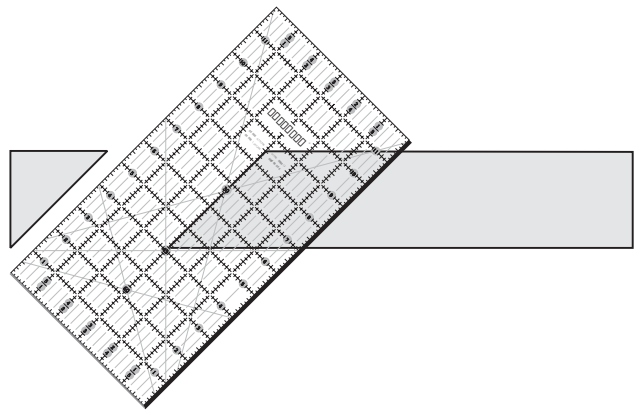

Continue cutting diamonds from the strip. After cutting three or four diamonds, use the 45° angle marking of the rotary ruler to double check the bias angle of the strip. You may need to trim the bias edge to correct the angle.

## Half Square Triangles

Before I begin the triangle discussion, I feel that I must first apologize to the vast majority of quilters that never cared for geometry and in all honesty never saw a real need to learn the information presented. The triangle information that follows is very simplified. If you really care to know how the formula works, study the diagram to better understand. If you are like the majority, just accept the theory, why the information is necessary, and memorize the numbers.

Half square triangles are literally triangles that are one half of a square. The square is cut once from corner to corner, diagonally. This places the grain of the fabric along the two short sides of the right triangle.

A half square triangle is one of the most basic shapes used in quilting. Therefore, it is very important to know when to use this type of triangle. Half square triangles are used whenever the short side of the triangle will fall at the edge of a quilt block or quilt top. This allows for the greatest stability and the least amount of stretch in these much-handled positions.

When working with templates, watch for the arrows that indicate grain (thread) lines. The location of these arrows will determine if the triangle is a half square triangle or a quarter square triangle (discussion to follow).

The formula below is **very** important for you to remember. It is the key to working with half square triangles!!

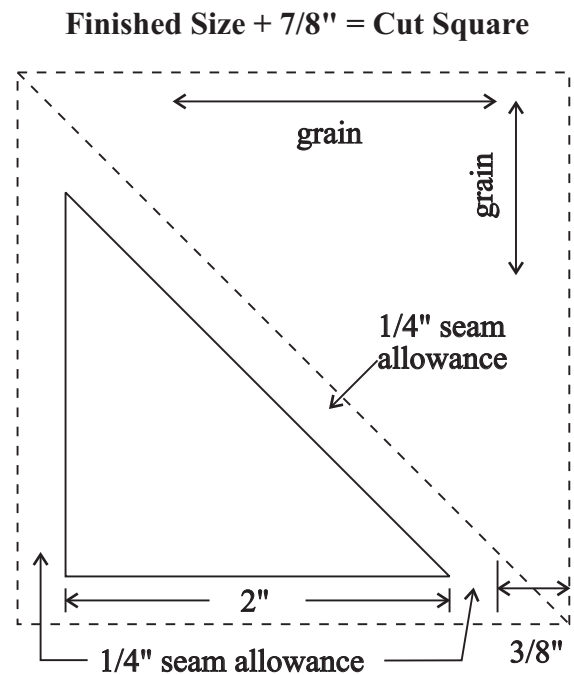

In the above diagram, 2" is the finished size of the triangle. As you can see, there is an additional 3/8" at the right that needs to be accounted for. Where does this 3/8" extension go when triangles are sewn together? These pieces are called "dog ears" and are trimmed from the completed unit. This eliminates bulk and prevents the shadow that a dog ear can create behind a light background fabric.

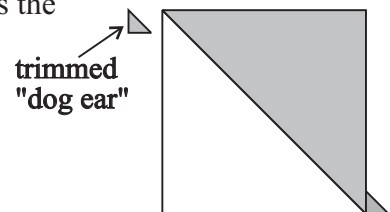

## Cut Once Diagonally

Fabric pieces that will be used as individual half square triangles will be cut as squares with the instructions to cut each square once diagonally as diagramed below. Cutting the square once diagonally places the stretch bias edge along the long side of the triangle.

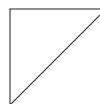

Cut the squares that precede this diagram once, diagonally.

## Quarter Square Triangles

Quarter square triangles are one quarter of a square. The square is cut twice from corner to corner - diagonally. This places the grain of the fabric along the long side of the right triangle. The 3/8" extension occurs on both ends on the long side in the case of a quarter square triangle. The formula for quarter square triangles is as follows:

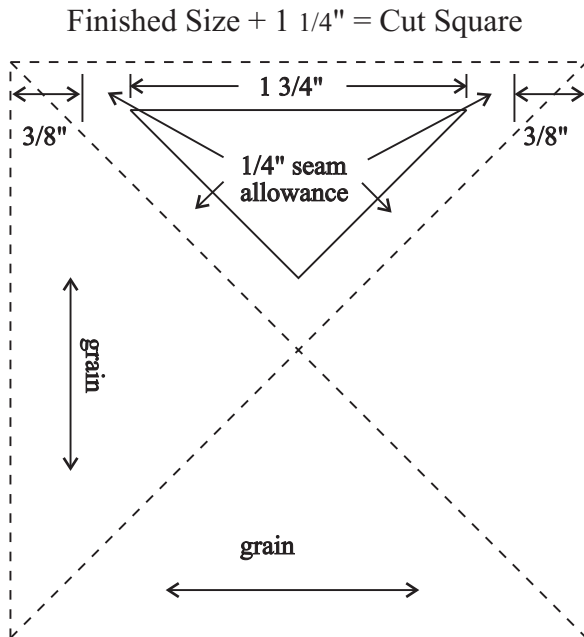

In the above diagram, 1 3/4" is the finished size of the triangle.

$1\ 3/4" + 1\ 1/4" = 3"$  The square is cut 3"

Quarter square triangles are not as common as their half square counterparts, but it is just as important to memorize the formula to avoid any possible mistakes that would place the bias along the edge of a block or quilt top.

## Cut Twice Diagonally

Fabric pieces that will be used as individual quarter square triangles will be cut as squares with the instructions to cut each square twice diagonally as diagramed below. Cutting a square twice diagonally, places the stretchy bias along the two short sides of the triangle.

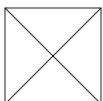

Cut the squares that precede this diagram twice, diagonally.

## Template Preparation and Use

Templates are necessary in the case of shapes that cannot be cut with a rotary cutter and standard rotary ruler. The pieces may be curved or involve angles that are not 30°, 60° or 45° angles.

Templates are generally made from frosted sheets of plastic that can be purchased at your local quilt shop. Template plastic is available with or without a 1/4" grid. The plastic can be easily cut with paper scissors or a rotary cutter.

Trace the template onto the plastic with a sharp pencil. I prefer to use a 0.5 mm mechanical lead pencil; it never dulls. It is helpful to use a small ruler to trace the straight lines.

You may find that taping the plastic in place with drafting tape while tracing the template is necessary. Drafting tape removes easily from paper and will not harm your original pattern or book.

Mark the grain line, if indicated, and all extra dots and lines that may be helpful as you construct the quilt block. On the template it is a good idea to note block details such as the block name, block size and template number or letter, if so titled.

Very carefully, cut on the drawn line. Once the template is cut, place it on top of the original to make certain that the template has not "grown". It is very important that the template does not change size, shape or angle.

Templates vary according to how they will be used. Some templates include the 1/4" seam allowance; some do not. Read each pattern carefully to determine how each is to be used. Each block pattern in this text will expand upon the information given above if a template is necessary for the construction of that block.



# Machine Piecing

## 1/4" Seam Allowance

All seams will be sewn with a 1/4" seam allowance. It is of utmost importance to establish and maintain an accurate 1/4" seam allowance. Because this is a sampler quilt and every block will be different, it is even more important that the 1/4" seam allowance is accurate. Some of you will already have quilting experience and feel confident that you know where your 1/4" seam is. I would encourage you to do the following exercise anyway. Just humor me if nothing else. I find that many of my students have misjudged their seam allowance and have been able to correct it with this exercise.

You will actually be sewing with a scant 1/4" seam allowance. The difference will be taken up in the slight fold or "ridge" at the seam.

To find your 1/4" seam allowance place a small ruler beneath your presser foot. When the needle is gently lowered, it should rest just to the right of the 1/4" mark on the right side of your ruler. If the needle were to pierce the ruler, the hole left by the needle would just graze the 1/4" ruler marking.

With the presser foot holding the ruler in this position, carefully pivot the ruler so the markings on the left side of the ruler run parallel with the markings on the throat plate of your sewing machine.

Once you are satisfied the ruler is positioned correctly, place a 1/2" x 3" strip of moleskin along the right edge of the ruler on the throat plate. Moleskin is a Dr. Scholl's® product, available at most groceries and pharmacies. The adhesive back of the moleskin will stick to the throat plate and give an edge to hold your seam allowance against. Moleskin gives more of an edge to follow than masking tape. Yet, it is not high enough that it will impede or pull out your pins.

## 1/4" Seam Test

Cut 3 pieces of fabric 1 1/2" x 6". Sew these strips together along the lengthwise edge. Press the seams in one direction. After pressing, check that there are no "accordion" pleats at the seams. Press again if necessary.

Measure your sewn unit; it should measure exactly 3 1/2" from raw edge to raw edge. The strips on either side should measure 1 1/4" and the center strip should measure 1" wide.

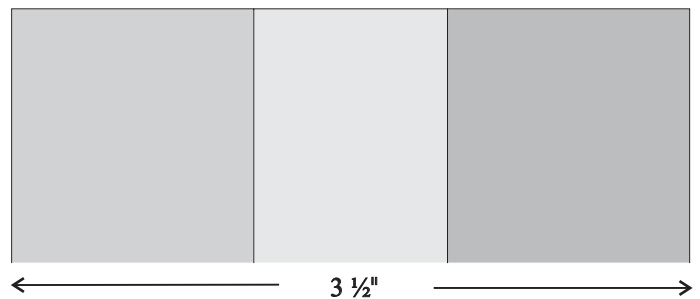

If your sewn unit doesn't measure exactly 3 1/2" you will need to adjust your moleskin. If the sewn unit is wider than 3 1/2" your seam allowance is too narrow and the moleskin should be moved to the right. If the sewn strip is narrower than 3 1/2" your seam allowance is too wide and the moleskin should be moved to the left.

The amount that you need to move the moleskin is only one fourth of the amount that your strip differs from 3 1/2". Two seams are involved in the sewn strip; each seam involves two pieces of fabric move the moleskin 1/4 of the difference.

It is a commonly held thought that the 1/4" seam allowance should be measured to check the accuracy of the stitching. Unfortunately, this does not work. The seam allowance is a scant 1/4". Measure the finished dimension of the fabric from the right side of the unit or quilt block.

If you have placed the moleskin exactly as described and are still having problems stitching a 1/4" seam allowance, it may be your sewing machine that is being naughty. The feed dogs of some machines pull to the right, some to the left. Sewing machines are an eccentric lot! Get to know your machine and work with its character flaws.

## Strip Piecing

Not all piecing is accomplished by sewing individual squares and triangles together. Many units can first be sewn together in strip form and then, after the strips are subcut, the resulting units will be stitched together to form the intended square.

The first step is to arrange the strips in the sequence that they will appear.

Begin by sewing strips together in pairs. This helps to reduce the arcing that can occur if strips are added to the strip set one at a time.

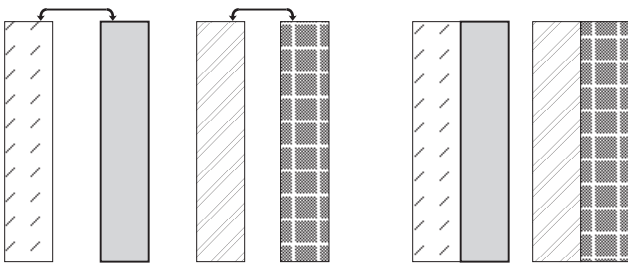

After each pair is sewn, press the strips flat from the wrong side. This smooths any wrinkles caused by poor thread tension. It also makes your strip moist (I always use steam when I am piecing) and pliable, so that the next pressing step goes more easily. You may have heard this called setting the seam.

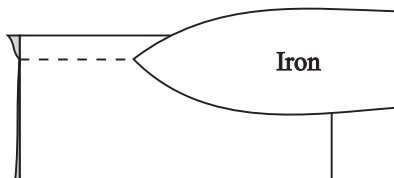

Once you have set the seam, open the fabrics and press the seam from the right side. Pressing on the right side gives the visibility required to prevent accordion pleating at the seam. The seam allowances should be pressed in one direction for the greatest strength, generally towards the darker fabric. Watch for arrows to indicate the direction the seam allowance should be pressed.

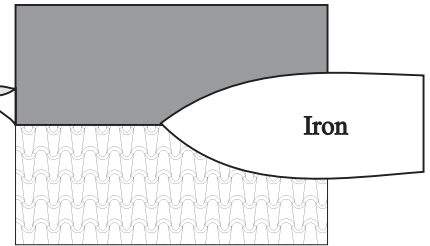

Stitch strip pairs together and press.

Press each seam as it is stitched rather than pressing all seams at one time to help prevent strip arcing.

Once sewn and pressed, the strips may be subcut into the units necessary to complete the piecing of the block. Place the strip right side up on the cutting mat. Align a perpendicular marking of the ruler with a seam line and cut the strip to the width called for in the pattern.

Reassemble the subcut units into the formation dictated by the pattern. Stitch and press.

## Chain Piecing

Chain piecing refers to the practice of stitching units one right after another without clipping the threads between the units. The first unit is stitched and left attached to the threads after passing under the presser foot. The second and following units are inserted under the presser foot one or two stitches after the previous unit has passed. No threads are cut.

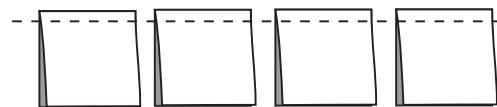

This method saves thread and the time required to start each unit as an individual. It also allows you to repetitively piece the same unit and create a rhythm, thereby reducing mistakes.

Clip the units apart and press.

# Triangulations™

## Half Square Triangles

Half square triangles are one of the most basic shapes used in quilting. Unfortunately, they are also one of the most often distorted shapes. Gridded triangles have long been present in quilting instructions. The use of gridded paper foundations greatly increases accuracy. Triangulations™ CD-rom is a great source for all your triangle foundation needs.

Print the number of triangle papers necessary.

Cut the fabrics as indicated in the individual pattern. The fabric piece cut will be slightly larger than the paper foundation.

Place two fabric pieces right sides together. Position a triangle paper on the **wrong side of the background fabric** and pin the paper to the fabric pair.

Starting at the large dot, stitch on all dotted lines. Follow the numbered arrows for a continuous seam. Use a small stitch (15 - 20 stitches per inch) and a size 14 sewing machine needle to better perforate the paper foundation.

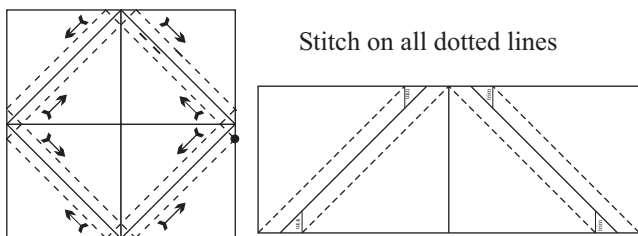

Cut on all solid lines using a rotary cutter and ruler. Each 6 1/4" pair will yield 8 - 2" (finished size) half square triangle units. Snip off the points of the triangles on the "trim" line indicated to remove dog ears.

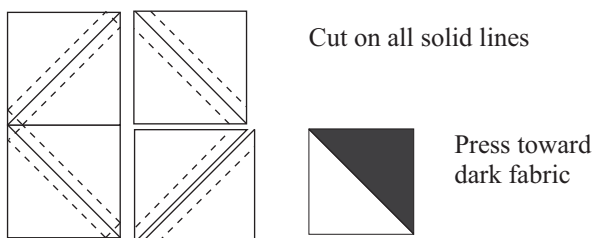

With the paper still attached, finger press the seam toward the dark fabric.

Remove the paper foundation. Place your thumb nail on the stitched seam at the center of the block. Pull the paper foundation from the square corner against your thumb nail. This will help to reduce the number of stitches lost at the seam ends.

## Quarter Square Triangles

Quarter square triangles are also often maligned. Triangulations™ CD-rom is a great source for all your triangle foundation needs. Quarter square triangle papers are used in the same way you would use half square triangle papers.

Place two fabric pieces right sides together. Position a triangle paper on the wrong side of the background fabric and pin the paper to the fabric pair.

Stitch on all dotted lines. Cut on all solid lines using a rotary cutter and ruler. Snip off the points of the triangles on the "trim" line indicated to remove dog ears.

With the paper still attached, press the seam toward the dark fabric.

Remove the paper.

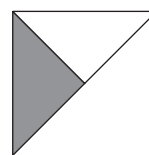
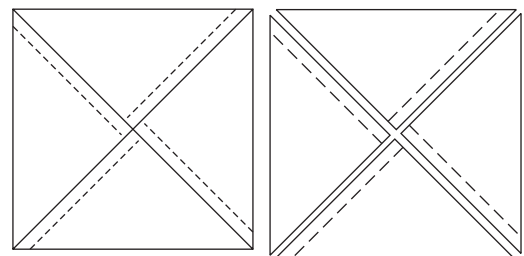

Each 4 3/4" square will create 4 units diagramed at left.

# Speedy Flying Geese

**This method is most accurate when the fabrics involved have been starched to a firm finish.**

Cut the fabrics as follows:  
**Geese - Triangle A:** cut the triangles as you normally would. The geese are cut from a square 1 1/4" larger than the finished products. The square is cut twice diagonally to yield 4 quarter square triangles.



finished size plus 1 1/4"

**Background - Triangle B:** cut the triangles from a square that is 1" larger than the cut size of the geese square. If the geese square is cut 5 1/4", cut the background square 6 1/4". Cut this square twice diagonally to yield 4 quarter square triangles.

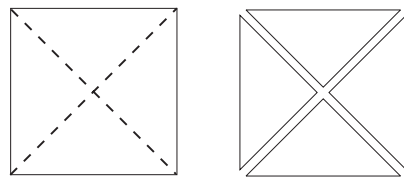

geese size plus 1"

Place each background Triangle B right side together with a Triangle A. The background triangle should be on top, with the square corner aligned. Stitch from the square corner to the point. Press the seam toward the background triangle.



Pair units from above, align the points. The center seam allowances will not line up!! Stitch along the bias edge using the standard 1/4" seam allowance.

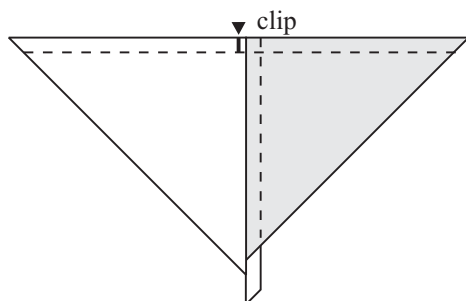

Snip the seam allowance at the center of the long seam, **cut just through the sewing line.** This will allow the seam allowance to be split and pressed away from each of the geese triangles. The stitched and pressed unit will look like the diagrams below.

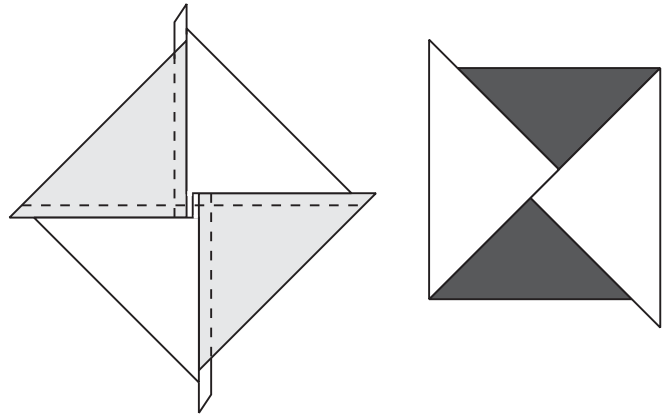

Cut the unit in half as diagramed. This cutting line will be 1/4" from the tip of each geese triangle, thus preserving the integrity of your 1/4" seam allowance when stitching geese to another unit. The cutting line will also be at a 45° from the diagonal seam. This cut will yield two geese units from the original.

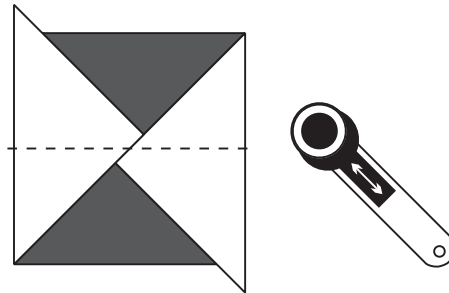

Trim the excess background fabric from the right of each flying geese unit. This excess will measure 1/2" wide. TaDa, you have just constructed two flying geese! A trimming template has been included for your convenience, should you feel the need to use one.

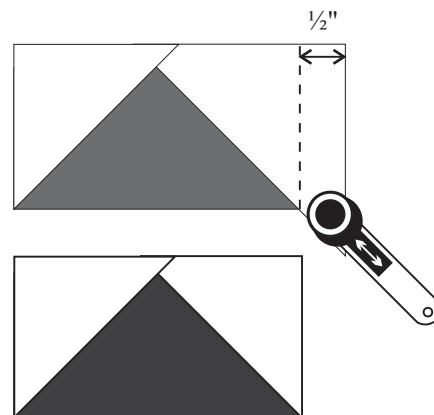

## Scrappy Triangle Unit

Two half square triangle units are each sewn to a rectangle. The two resulting units are sewn together, and subcut - creating two identical scrappy triangle units. This greatly speeds piecing of this versatile unit.

Stitch 2 half square triangle units each to a 2 1/2" x 3 1/4" rectangle of background fabric. Press the seam toward the rectangle.

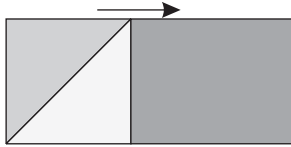

Stitch two units together. Match the raw edges. The seams will not match.

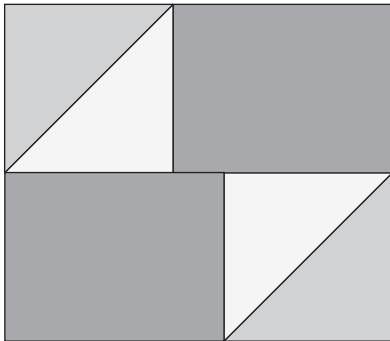

Carefully snip the seam allowance through the seam line at the center of the long seam. This will allow the seam allowance to be split and pressed in two different directions. Split the seam and press the seams toward the rectangles.

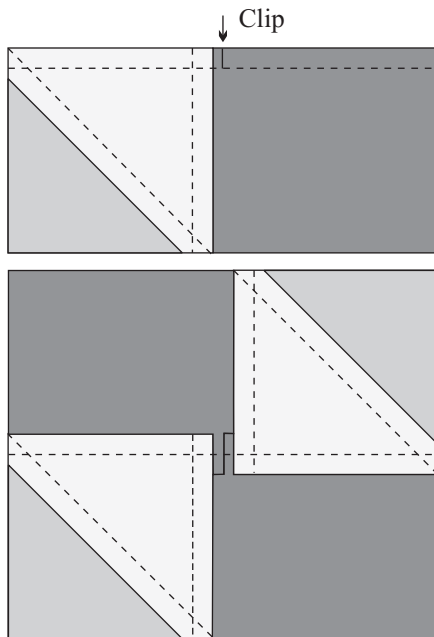

Place the pressed unit, right side up, on the cutting mat. Align the **Omnigrd #96** ruler as diagramed below. Line up the 4" ruler marking with the left edge of the pieced unit. The 1 3/4" ruling will fall along the center seam, and the point of the ruler will extend past the fabric edge, allowing the "nub" line to align with the edge. Cut the pieced unit along the diagonal edge of the ruler, creating two identical scrappy triangle units. A trimming template may be used if you do not have access to the **Omnigrd #96** ruler.

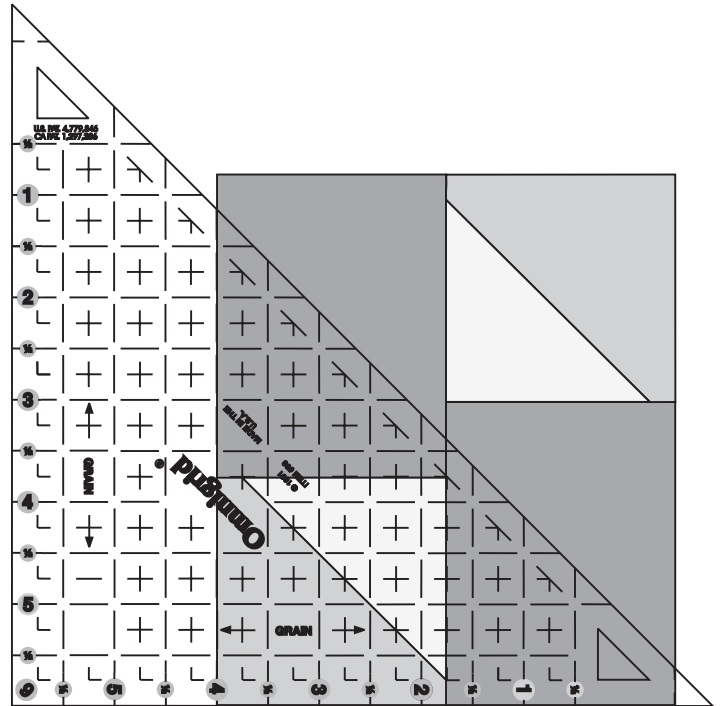

## Sew 'n Flip

The sew 'n flip method of piecing is a quick and accurate way to add a triangle corner to squares or rectangles without the need for numerous, odd shaped templates. The shapes cut are simple squares and rectangles. This allows you to make the cuts with your rotary cutter and ruler.

Place the square on top of the larger square or rectangle, right sides together. Begin stitching exactly at the corner of the smaller square and stitch from corner to corner, diagonally. This line may be drawn on the wrong side of the smaller square with a pencil or the smaller square may be pressed diagonally to create a crease at the sewing line.

Fold the sewn square along the seam to verify that the edges match, i.e., that the seam was sewn properly. If the raw edges do not match, remove the seam and stitch a corrected seam.

When you are satisfied that the seam is correct, trim the excess fabric to a 1/4" seam. This can be done with scissors or a rotary cutter. Press the seam as indicated by the individual pattern.

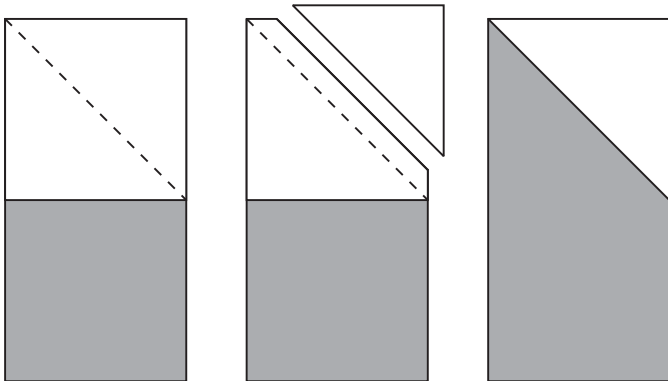

## Foundation Paper Piecing

Foundation piecing has been introduced because of the unusual shapes in some of the blocks. This eliminates the need to cut and trace templates, thus speeding the process and increasing accuracy.

### Points to Remember

Each master foundation is meant to be used as a pattern to create the foundation papers that you will stitch through. A photocopied foundation may be distorted. Always compare the copy to the master and make all copies needed from the same machine. If the copy varies significantly from the original, discard the copy and try a different copying machine.

It is helpful to use a larger sewing machine needle, such as a size 14 needle.

Stitch with a shorter stitch length, 15 - 20 stitches per inch, to better perforate the paper.

The lines on the pattern are the actual sewing lines. Sew directly on these lines.

The fabric pieces will be placed on the unmarked side of the foundation paper, and the seam will be sewn from the marked side.

The fabric pieces do not need to be cut precisely. After stitching, the excess will be trimmed to a 1/4" seam allowance. Take care to allow sufficient fabric to cover the area.

Each block is diagramed with the numerical sequence of fabric application.

The foundation pattern will be the mirror image of the final product!!

## Foundation Piecing Steps

Photocopy or trace the foundation piecing designs. If you choose to trace the designs, artist vellum works well.

Trim away the excess paper from the copied design, leaving 1/8" beyond the outermost line.

Cut a piece of fabric for Section 1. The piece should be cut slightly larger than the area, allowing at least 1/4" for the seam allowance on all sides.

Place the wrong side of the fabric piece against the unmarked side of the foundation paper. Position behind Section 1 and pin in place.

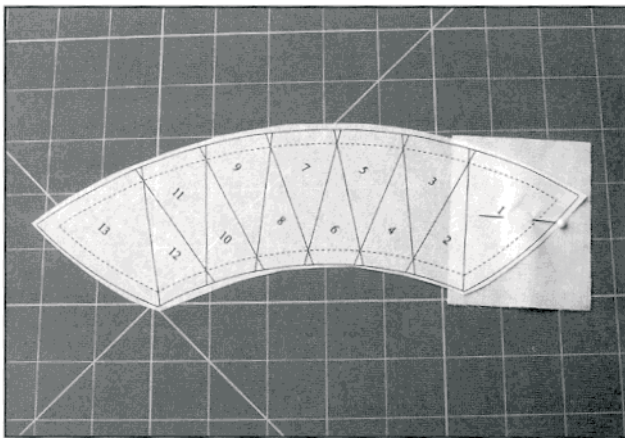

Flip the assembly to expose the right side of fabric 1 and the unmarked side of the foundation paper.

Cut a piece of fabric for Section 2. Allow 1/4" for the seam allowance on all sides. Position on top of Section 1 fabric, right sides together (r.s.t.).

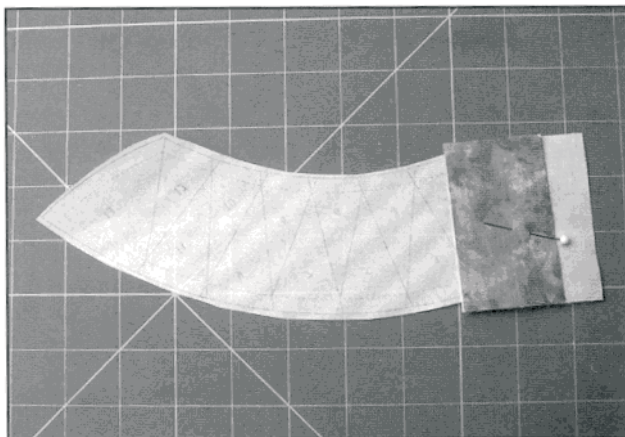

Flip the paper/fabric assembly over. With the marked side of the foundation facing up, stitch on the seam line between sections 1 and 2. Stitch past the end of the seam line on each end to anchor the fabric. There is no need to backtack; the stitches are small and will not be pulled out.

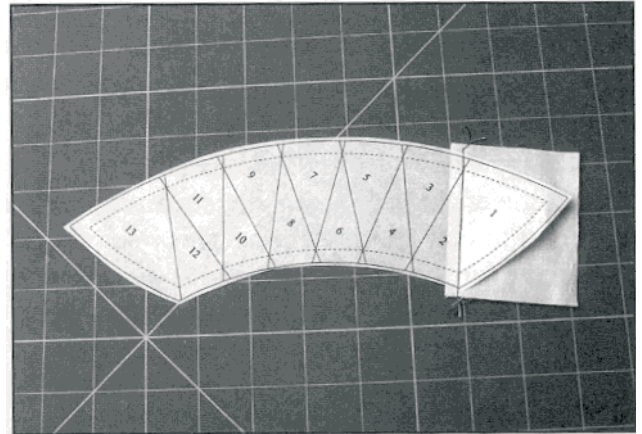

Finger press the seam to eliminate all pleats or carefully press the seam using an iron without steam. This is a very important step. A poorly pressed seam may mean disaster later.



Flip the paper/fabric assembly over to reveal the printed paper again. Place a postcard along the seam line between Sections 2 and 3.

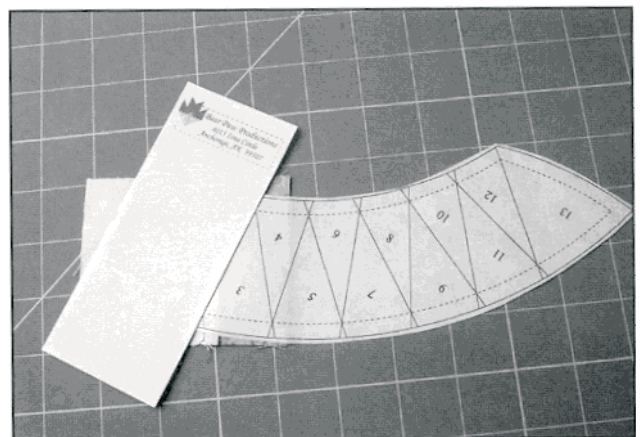

Fold the paper over this stiff edge and cut away the excess fabric 1/4" from this folded edge. You may use any small ruler with 1/4" markings. I prefer to use an "ADD-A-QUARTER" ruler. The 1/4" wide lip of this ruler fits snugly against the folded edge giving a consistent 1/4" seam allowance.

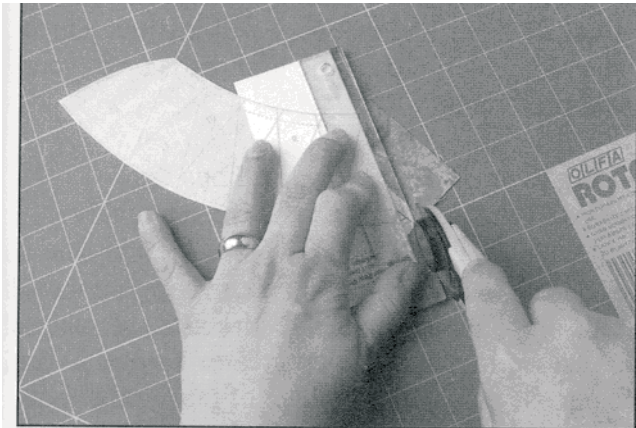

Open the folded paper, and flip again to reveal the fabric pieces. Place fabric 3 in position, raw edges even with the newly cut edge, r.s.t.

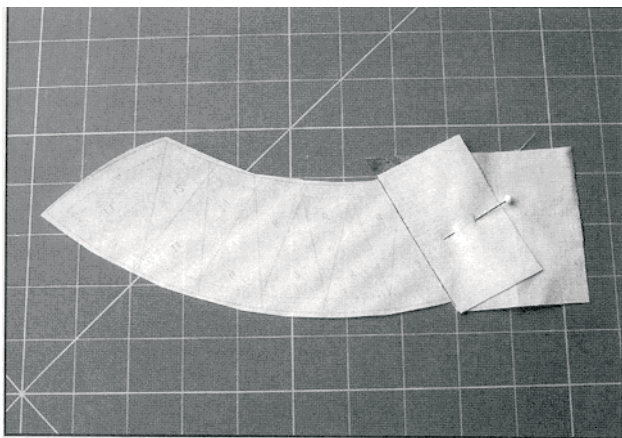

Continue adding pieces until all sections have been completely covered. Trim the edge of the block along the outermost line, leaving a 1/4" seam allowance.

After trimming, remove the foundation paper. Pinch the beginning of the seam between the thumb and forefinger of your "wrong" hand and gently pull away the paper, placing all excess force against the thumb nail holding the seam down. If removed

gently in this manner, stretching and pulled stitches will be kept to a minimum.

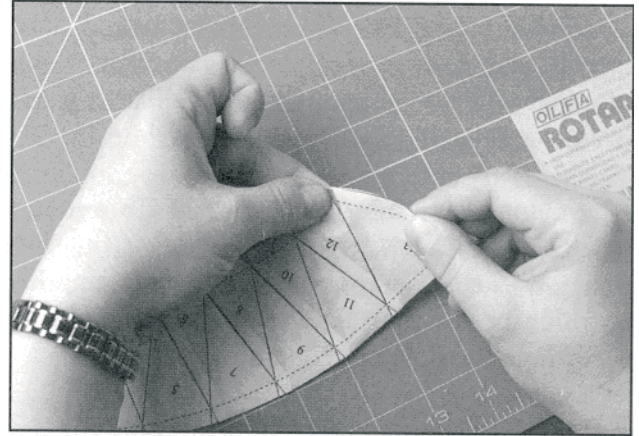

Stitch the block units together after completing the paper pieced portion of the block construction.

## Curved Piecing

To prepare for curved piecing, make plastic templates as directed by the individual pattern. It is helpful to cut the fabric pieces from squares or strips. This will place the grain along the straight edges of the blocks and the bias along the curved edge where it will be the most beneficial.

Cut the fabric pieces as directed by the individual pattern. Fold the pieces in half and lightly finger crease the center of each curved edge to mark the center of the seam.

Match the centers of the pieces and pin to anchor. Line up the straight edges and pin at each end.

Stitch with the concave piece on top. Using a stiletto, or the point of a seam ripper, coax the concave edge into alignment as you stitch a 1/4" seam. Do not stitch more than 1/2" to 1" at a time before you realign the edges. Press as the pattern directs.

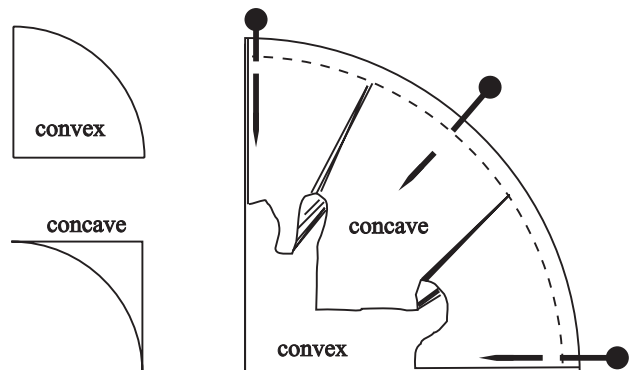



## Set-in Seams

Set-in seams are used at intersections where 3 separate seams come together. These seams require that you stop stitching at the 1/4" seam allowance and backtack.

Mark the intersection of the 1/4" seam allowance with a dot at each corner involved in the set-in seam. This may be done using the 1/4" ruling of a small rotary ruler, or you may cut a template and make a mark through the dots on the template.

Use a pin to align the marked dots on each diamond. Stitch the pair together. Start at the dot, backtack, and sew to the opposite edge. Do not let one stitch extend beyond the dot into the seam allowance!!

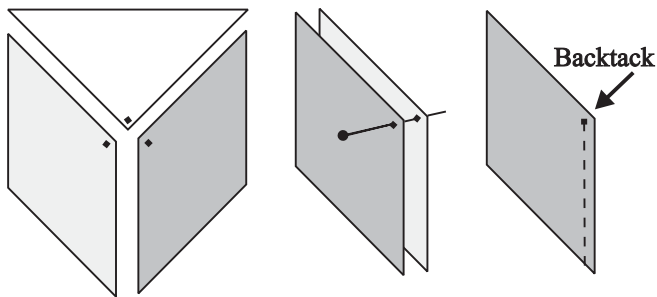

Align the point of a quarter square triangle with the left diamond. Use a pin to line up the marked dots. Stitch from the point to the dot and backtack. Do not catch the first seam allowance.

Remove from the machine and position the next seam. The first seam allowance will be pushed out of the way and not stitched down. Stitch from the dot to the point. Press as diagramed.

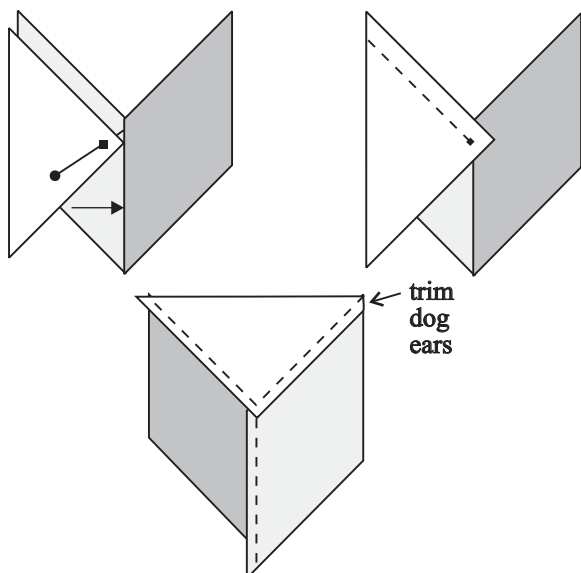

## Pin and Match

My personal feeling about pins is that I will use them only when absolutely necessary. In most cases, seams can easily be stitched without the assistance of a pin. At other times, the pinning of seams is a necessary evil. If I feel that pins are important for a particular seam I will instruct you to pin. The remainder of the time pinning is up to your personal preference.

**Opposing Seams** - Generally, methods are employed to ensure that the seams match nicely without the use of pins. This involves pressing the seams in such a manner that the seams oppose - i.e., the seams are laying in opposite directions. A seam that is pressed in one direction creates a ridge. When seams oppose we take advantage of those ridges and make the seams butt up against each other. This will also distribute the bulk of the seam.

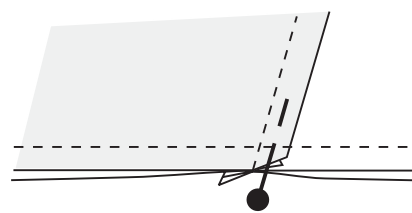

When sewing a seam such as this, pin the seam allowance that will be crossed first. Once the needle has reached the seam allowance, remove the

pin. The seam should not shift at this point.

**Do not** sew over pins! If the sewing machine needle hits the pin, the machine can be damaged. The broken needle may fly into an unprotected eye!

**Stab Through Pinning** - This method is employed when very specific points must match. A pin is "stabbed" through the two points that must match, then anchored. As the units are sewn together, the seam will pass through the point that the pin was securing.

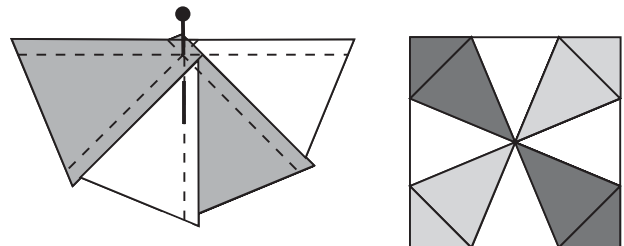

## Pinwheel Seam Allowances

This method of distributing the bulk of the seam allowances is used a number of times in the construction of the blocks.

Press the seam toward the dark fabric.

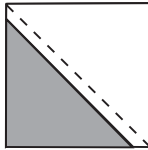

Stitch two block halves together. The seams on each will be opposing. Stab pin through where the points intersect, right sides together. Stitch the long seam. Be sure to stitch through the pinned intersection.

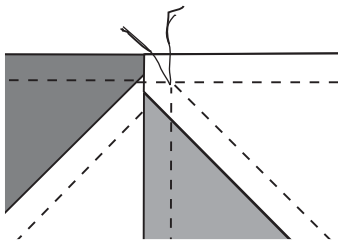

After checking that the points match, pull the two or three stitches of the vertical seam that extend past the long seam into the 1/4" seam allowance. This will allow the final seam to be swirled and pressed so that all of the seams are rotating in the same direction, distributing the bulk in the center of the block.

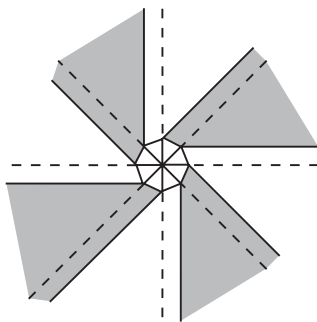

## Pressing

Seams are generally pressed toward one side, rather than open as in clothing construction. Most often the seam is pressed behind the darker fabric. BUT, all rules are made to be broken!! The instructions given in this book include precise pressing directions, generally in the form of arrows. Care has been taken to ensure that seams oppose if possible and that seam allowances lay behind the darker fabric.

Often, a choice must be made whether the seam allowance will be pressed toward the darker fabric or toward the least resistance. At these times, it is usually better to press the seams in the direction of least resistance.

When seams are pressed, first press the seam flat from the wrong side. This smooths any puckers caused by thread tension problems. Then, open the layers, press from the right side and watch for any pleating at the seam.

Pressing is a personal topic. Fabric prepared with spray starch can be finger pressed. Finger pressing is a temporary method of creasing the seam with your thumb nail. Care must be taken to prevent any excess fabric from being left in a fold at the seam. I would encourage an occasional trip to the ironing board. Blocks that are steam pressed as they are sewn tend to lay flatter!!!

# Appliqué

Appliqué is known among some quilting circles as the "A" word. As a machine piecer, I tend to look for methods that will employ the sewing machine to make appliqué easier and more efficient. The directions given below pertain to machine appliqué in a general sense. The individual block instructions will detail how the appliqué technique is to be used.

## Machine "Hand" Appliqué

Trace and cut applique templates from template plastic. Appliqué templates do not include seam allowances!

Trace the templates onto the paper side of freezer paper. Cut the freezer paper on the drawn line. It is important to cut the shapes smoothly. You can cut multiple layers of freezer paper at one time. Layer the paper and staple the layers together to prevent shifting.

Place the shiny side of the freezer paper against the right side of the fabric and press in place with an iron on the "wool" setting. This will cause the freezer paper to lightly adhere!

Cut out the fabric shapes 3/16" (a scant 1/4") larger than the freezer paper. Remove the freezer paper from the right side of the fabric.

Place the freezer paper, shiny side up, on the wrong side of the cut fabric piece. With the tip of a warm iron, carefully roll the seam allowance over onto the freezer paper template. Press the fabric in place until the seam allowance adheres. This will hold the seam allowance in place until it has been stitched. Fabric sections that will be layered under a second piece of fabric need not be turned under. Roxanne's Glue-Baste-It! may also be used to baste the seam allowance to the freezer paper template.

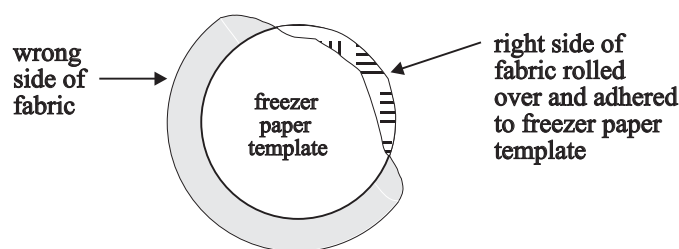

Baste the fabric shapes, with the freezer paper still attached, into place on the background fabric. Pins or Roxanne's Glue-Baste-It! work well for this application.

Machine stitch the pieces in place using clear .004 nylon thread on top. Practice the stitches described below to determine the one you prefer.

Blind Hem Stitch      width 1.25  
      length .5

Zig-Zag Stitch      width 1  
      length 1

The right swing of the needle is off the edge of the appliqué and left swing of the needle is fully on the appliqué fabric.

Loosen the tension of the top thread to prevent the bobbin thread from popping up to the surface of the background fabric. If this cannot be remedied, match the bobbin thread to the background fabric.

Use an open toe embroidery foot if available. The open toe allows you to see the needle clearly.

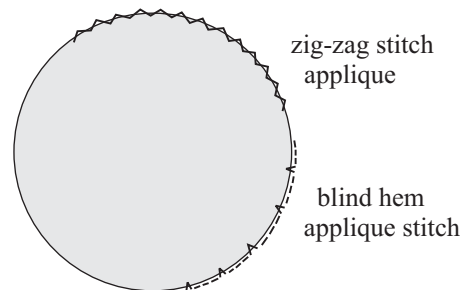

After all the appliqué pieces are stitched in place and the block is completed, the freezer paper templates will need to be removed. Carefully make a cut in the background fabric behind the stitched applique and remove the freezer paper through the opening. If desired, the background fabric can be removed from behind the appliqué design, by trimming background fabric from the wrong side of the block, leaving a 1/4" seam allowance.

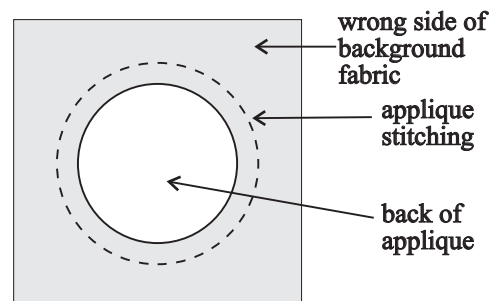

# Finishing

## Borders

All of the quilts in this book were constructed using square borders. The application of a square border is easier to master than the application of a mitered border.

### Primary Borders

Primary borders are all border strips that are applied to the quilt top before the final border. They may be very narrow, wide, piped, or even pieced. All primary borders for the quilts in this text were cut as crossgrain strips and pieced together using diagonal seaming. Diagonal seams in the border strips are less visible than straight seams. No effort is made to place the seams in any particular position.

To make a diagonal seam, place the first strip right side up. Position the second fabric strip right side down, on top of the first strip. The second strip will be placed at a right angle to the first. Stitch diagonally across the strip ends. Trim the excess to 1/4" and press the seam to one side. All of the "First (Second or Third) Border" strips are sewn together to create a long strip, and lengths are cut from it.

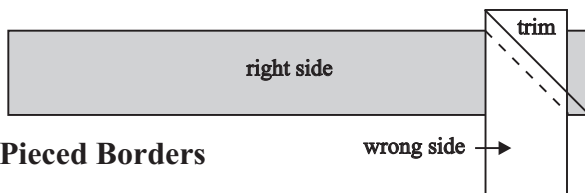

### Pieced Borders

A pieced border is generally one of the primary borders. It is a wonderful addition to a beautiful quilt. A pieced border must be mathematically correct to fit the quilt top. The pieced diamond border on Flannel Fling is mathematically correct if your piecing is accurate. If your piecing has been less than accurate, it is possible to adjust the vertical seams of the border strip to accommodate the difference. Unfortunately, this will also adjust where the points of the pieced border fall.

### Piped Border

Piped borders are especially fun in places that you would like a little "hit" of color. The piped border strips are pieced diagonally to create a long strip. Trim the excess fabric to 1/4" seam allowance and press these seams open. Press the 1" wide strip in half lengthwise - wrong sides together. This will result in a 1/2" wide strip.

The piped border strips are cut to length and basted to the edge of the quilt top, raw edges even. The strips will remain in this position, with the fold toward the center of the quilt. After the next border is applied, the piped border will measure 1/4" wide.

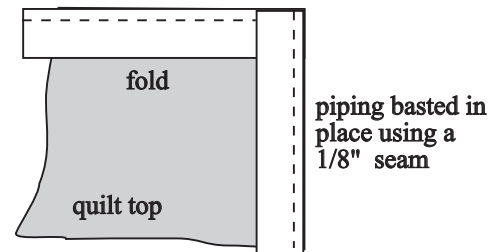

### Final Border

The final border is cut from the lengthwise grain of the fabric. This will require extra yardage to be purchased, but it is well worth the expense.

The lengthwise grain of the fabric is more stable than the crossgrain. This extra stability will go a long way toward preventing stretching and ruffling of the quilt edge due to handling.

To cut a lengthwise fabric strip, measure the inches of fabric called for in the directions, and cut the yardage to that length. Fold the fabric crosswise, until it is narrow enough to be spanned by your rotary ruler. The folded fabric will have selvage at either edge. The first cut will be to remove the selvage. Cut the border strips to size. Use the rulings on the cutting mat if your ruler is too narrow.

## Applying Borders

The individual quilt instructions in this text do not give exact measurements for the borders. The strip measurements given are longer than what would be mathematically correct. No matter how carefully you have pieced, over the course of **many** seams, variations can and do occur! It is not uncommon for the sides of a quilt top to have stretched with the handling that they have received, or even measure differently. These variations need to be addressed if you wish to have a square quilt that lays flat.

To accommodate the variations, do not cut a strip to the length that is mathematically correct, and do not stitch a long length to the side of the quilt top and cut it off where the edge of the quilt lands!!

### Measuring

When adding borders it is important to measure the "body" of the quilt top, not the edges of the quilt that may have stretched.

Press the quilt top carefully. When measuring, it is important that the quilt lay as flat and smooth as possible.

Measure from top to bottom through the center of the quilt with a metal measuring tape. My sewing bag contains a petite 10 foot tape measure. Cut the two side borders to that measurement.

Pin the border strips in place along the sides of the quilt top. Match the center of the border strip to the center of the quilt top. Use as many pins as needed.

Stitch the border strip to the quilt top. You are making the quilt top fit the border strip! Stitch with the border strip on top. The feed dogs will help to ease in the fullness of the quilt top if necessary.

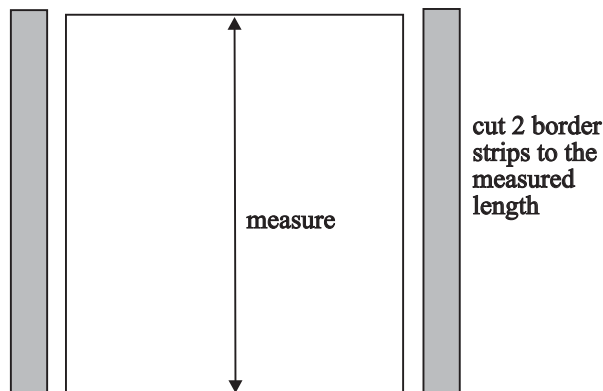

From the right side, press the seams toward the border strips.

Lay the quilt on a flat surface and measure the quilt top from side to side through the center of the quilt, including the border pieces that you just added. Cut the top and bottom border strips to that measurement.

Pin and stitch these borders in the same manner that the side borders were added.

Press the seams toward the border strip.

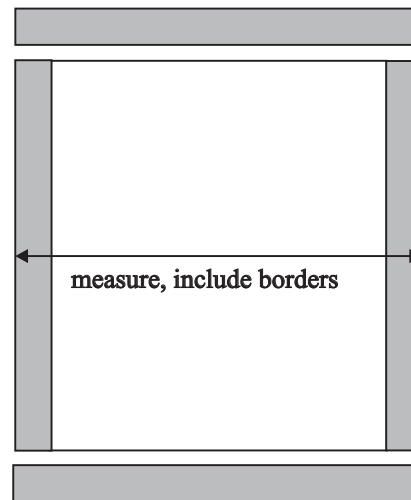

All borders will be added in this manner. When applying the final border, backtack the seams that will be exposed at the raw edge of the quilt. This helps to prevent the stitches from pulling out as the quilt top is layered and quilted. The quilts in this book have had the side borders applied first, and then the top and bottom borders. This order of border application is generally a more economical use of fabric - a shorter yardage of fabric is required.

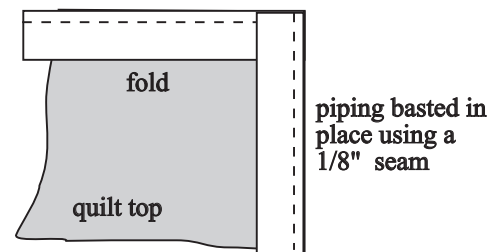

## Backing

How to prepare the backing is a matter of personal taste. Many quilters use the left over scraps of the quilt top to piece together a scrappy backing. If you are planning to hand quilt the layers, a pieced backing may not be the best idea. The many seams might be difficult to "needle". Fortunately, fabric manufacturers are thinking about backings, and have made available fabric that is 100" - 112" wide. This fabric is very easy to use; simply cut to size. There are no seams to make the quilting process difficult.

Select a backing fabric that is a good quality cotton. Do not purchase a poor quality piece of fabric because it is less expensive. The backing needs to wear as well as the quilt top. A bed sheet really is not an ideal quilt backing. The fabric of a bed sheet is very tightly woven, and will make hand quilting a chore, perhaps even a painful experience.

The effect of the backing fabric color needs to be considered. If a polyester batting is used, a dark backing fabric may show through, dulling the light or bright colors of the quilt top. If the backing is patterned, the quilt top may appear splotchy! Cotton batting is more opaque and will allow less shadowing.

### Yardage Requirements

Backing should be 6" - 8" larger than the completed quilt top. Yardage is figured on 43" of usable fabric width after preshrinking and removing the selvages. Measure the quilt top to determine the length and width.

widths up to 37"	length + 6"
widths 38" to 80"	(length x 2) + 12"
	Remove the selvages and sew one lengthwise seam. Press to one side
widths greater than 80"	(width x 3) + 18"
	Remove the selvages and sew two crosswise seams. Press to one side

Press the seam open if you plan to hand quilt.

## Batting

Batting is the layer of filling between the quilt top and the backing. There are many weights and types of batting available on the market today. It is available in polyester, cotton, cotton/polyester blends and even wool. Batting is available packaged in standard sizes or as yardage from a bolt. Some are better suited to hand quilting while others are best left for tying.

### 100% Cotton or Cotton/Polyester Blends

The cotton battings will give a more traditional look to your quilts. 100% cotton batting generally requires more quilting than a polyester batting would, but batting manufacturers are constantly upgrading and improving their product. Cotton batting is available today that can be quilted 8" apart!

Cotton batting is my personal favorite. I prefer the antique look that the cotton batting gives. Cotton batting hand quilts nicely and is a great choice for machine quilting. As you select and purchase batting, my best advice is to read the package!! Know what you are working with to prevent disappointment.

## Quilting

Quilting is the process by which the three layers of the quilt (top, batting and backing) are held together. Quilting can be accomplished by hand or by machine. And, if you have no inclination to quilt, the three layers can be held together by tying.

The quilts that I pieced and tied 20+ years ago wore out quickly. The layers were tied together. This allowed the layers to move independently, hastening the aging process. If a quilt is heavily quilted, the layers will not have the opportunity to move independently, and as a result, the quilt will enjoy a longer life.

Entire books are available on the subject of quilting, both hand and machine. I will refer you to your local quilt shop. They can help you find the text that you need.

# Binding

Binding is the process of finishing the edge of the quilt after it is quilted.

## Preparation

Baste the edge of the quilt top down. This can be done with a long, wide zig-zag stitch on the sewing machine. This basting will prevent excess shifting of the quilt top layer at the edge as the binding is applied.

Trim the batting and backing 1/8" beyond the raw edge of the quilt top. This extra fabric and batting will fill out the binding and prevent empty spaces.

Piece the cut binding strips together using a diagonal seam. Trim the seams to 1/4" and press the seams open.

Press the long binding strip in half lengthwise, right side out, to a width of 1 1/4".

Position the folded binding strip so that its lengthwise raw edges are even with the raw edge of the quilt top. Leave 8" free, and begin stitching the binding to the quilt a few inches beyond the center of one edge. Stitch with a 3/8" seam allowance; back tack to secure the seam. Stop stitching 3/8" from the edge and back tack. Remove the quilt from the sewing machine, and snip threads. Rotate the quilt to prepare to sew the next edge.

Fold the binding strip up, away from the quilt, it will fold nicely at a 45° angle. Fold it again to bring the strip edge along the raw edge of the quilt top. This fold should be even with the top edge of the quilt. Begin stitching at the fold, stitch through all layers.

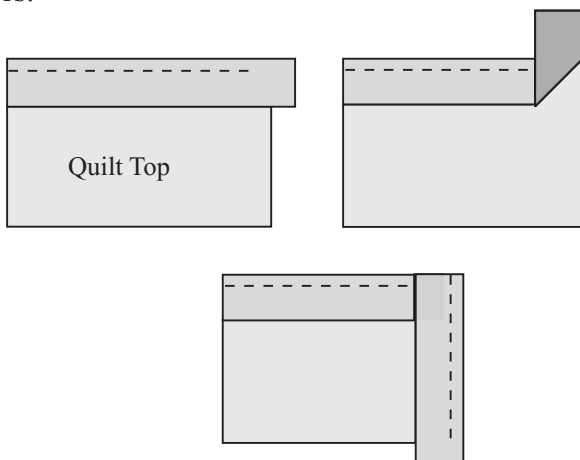

Continue sewing around the quilt in this manner until you are within 12" of the starting point; back tack.

To finish the quilt, fold each strip back on itself so that the folds meet in the middle of the 12" gap. Finger press a crease at the folds.

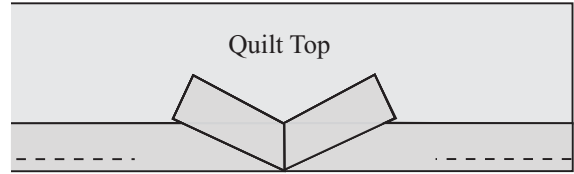

Trim the excess strip fabric 1 1/4" from both folds.

Open the folded strips and place the strips right sides together as diagramed below. Fold the quilt out of your way to allow the binding strips to be aligned properly. Stitch the strips together with a diagonal seam. Trim the seam allowance to 1/4" and press the seam open.

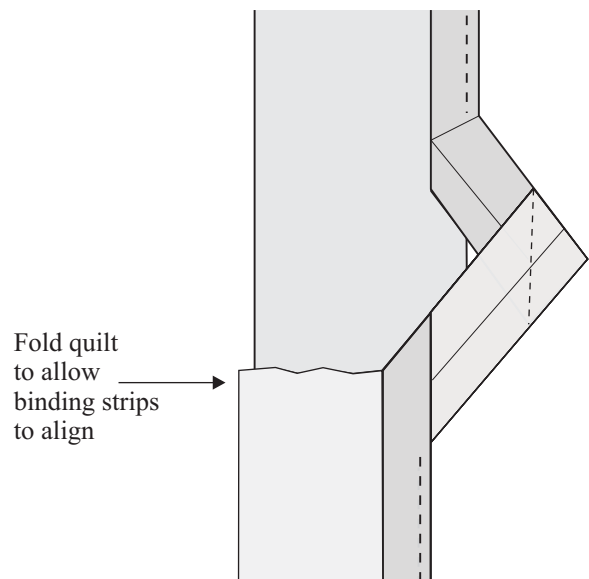

Fold the binding strip together again and finish stitching the binding strip to the edge of the quilt.

Hand stitch the folded edge of the binding to the back side of the quilt with a blindstitch. Use a thread that matches the binding. The fold of the binding should just cover the seamline.